

M3

Outdoor Card Controller

Quick Guide v1.0

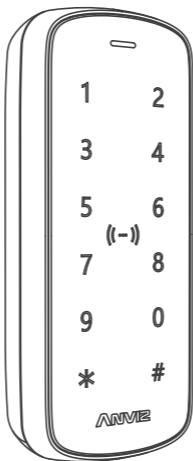

www.anviz.com

The products are subject to change without notice.

Package List

1 Controller

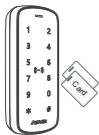

2 Instruction Package



3 Accessory Package



X2



X1

4 Connector Jack



RJ45

USB

Installation Diagram

Back panel install way:

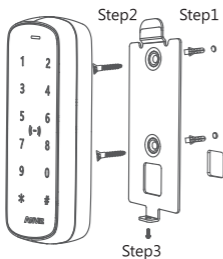

Steps:

Step1: Drill holes in the wall follow the hole position on back panel.

Step2: Install and fix back panel, connect related cables.

Step3: Place M3 on back panel, fix screw at the bottom of M3.

Without back panel install way:

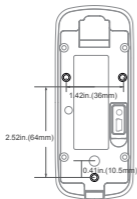

Steps:

Behind the wall fix M4 screws directly to the bottom shell, the depth of screws is 8mm.

This install method is unique, safe and convenient. Package list has no these screws, according to wall thickness select the length of M4 screws.

Appearance

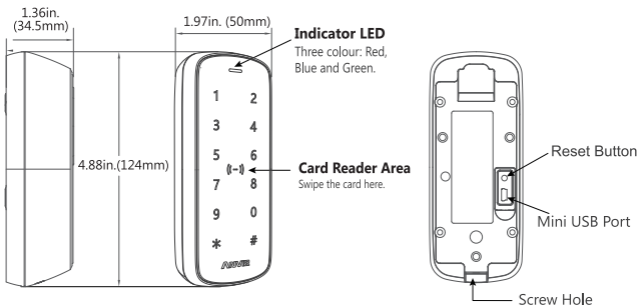

Wiring Instruction



Connect RJ45

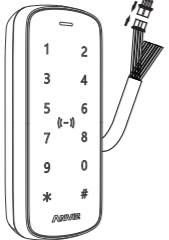

Function	No.	Cable Color	Description
Power	①	Red (Heavy Line)	DC12V
	②	Black (Heavy Line)	GND
Tamper alarm <small>(Dry contact output signal, do not connect with electric equipment)</small>	③	Pink(Heavy Line)	Tamper alarm
	④	Black	Exit Button
Wiegand26 Output	⑤	Green	Wiegand DATA0 Output
	⑥	White	Wiegand DATA1 Output
Pulse signal	⑦	Brown	Door Magnetic
	⑧	Light brown	RS485A
	⑨	Light blue	RS485B
Relay Output	⑩	Blue	NO
	⑪	Light green	COM
	⑫	Orange	NC



Important notice: Please follow the wiring diagram as it is displayed. Damaged products due to improper wiring are not covered by product warranty.

Access Control Reader & SC011

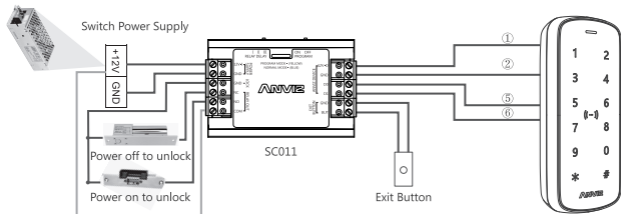

SC011 can work with M3 by Anviz encrypt Wiegand code authorized to set up a distributed access control system. You can buy SC011 from our sales.

Access Control Reader & Access Control Power Supply

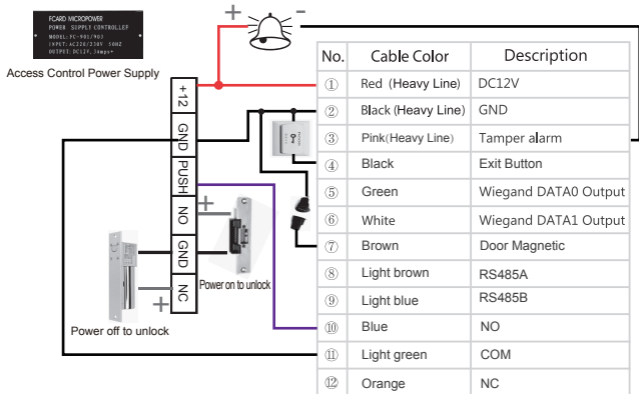

Access Control Reader & Switching Power Supply

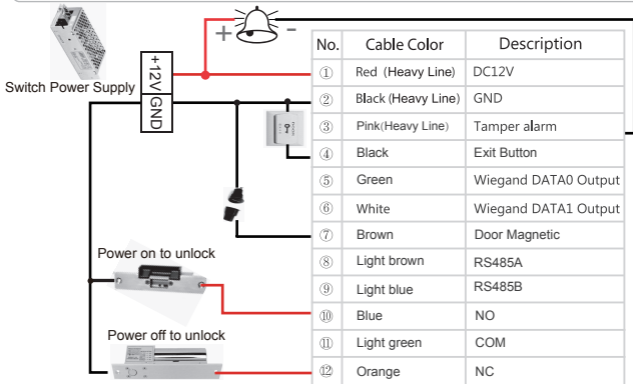

Operation Guide

■ Activation:

Touch front of M3 with back of hand or fingers to activate. M3 will turn off again in 10 seconds if there are no other operations.

■ Enter main menu:

After activate M3, press key '*' then input '0' as ID and press '#', input default admin password '12345' and press '#' key to enter management menu.

***Pay attention:** Please change to your safe admin password, because factory default password is the same, it's not safe.

■ Change default admin password:

In main menu, press key '0' then input new password and key '#' twice. (New password is 1 to 6 digits number.)

■ Programming:

User ID number: It can be 1 to 4 digital number.

User PIN code: It can be 1 to 6 digital number (To be safe, please set up 6 digital).

Basic programming steps:

1. Activate M3, then input admin ID and password enter into main menu.
2. Input number to select functions and follow these operation steps:

Function	Function number(Press follow key firstly)	→ Other operation steps
Change admin	0	1. Input new password+"#" 2. Input the same new password again+"#"
Add user	1	1) Swipe card: Swipe 1st Card→swipe 2nd Card→swipe 3rd Card→.....+"#" 2) ID+ PIN code: Input 1st user's ID+"#"and PIN code+"#"→Input 2nd user's ID+"#"and PIN code→.....+"#"
Delete user	2	1) Swipe card: Swipe 1st Card→swipe 2nd Card→swipe 3rd Card→.....+"#" 2) User ID: Input 1st user's ID→Input 2nd user's ID→.....+"#" 3) All Users: Input 0000+"#"
Verify mode to open door	3	1) Card or PIN code(Factory default): Input 0+"#" 2) Card: Input 1+"#"
Delay time of electric lock	4	Input 0 to 30 +"#" to set lock delay time.(Factory default: 5 Seconds)
M3 work mode	5	1) Access controller(Factory default): Input 0+"#" 2) Reader: Input 1+"#"
Door magnetic	6	1) Turn off door magnetic function(Factory default): Input 0+"#" 2) Turn on door magnetic function: Input 1+"#"(In this mode, if door was opened over 15 seconds, the buzzer in M3 will ring.)
Tamper alarm	7	1) Turn off tamper alarm function(Factory default): Input 0+"#" 2) Turn on tamper alarm function: Input 1+"#"(In this mode, if M3 was disassembled, the buzzer in M3 and external alarm will ring .)
Reset to factory defaults	9	Input 000 +"#" (When you want to delete all the registered administrators and users and let M3 back to the factory default settings, you can reset it .)

***Pay attention:**

1) Card function can work only supplied by DC12V power, when connect M3 with PC by Mini-USB cable can't swipe card.

2) Multifunctional key "": return to previous.

3) PIN code verify operation: After activate M3, input ID + “#” key firstly, then input right PIN code + “#” key , the door can be opened.

LED & Buzzer status

Status	LED	Description	Buzzer
1	Blue LED flashes and number keys light	Activation status.	Buzzer not ring
2	Green LED lights	Register or verify or delete user such as these settings successfully	One Beep
3	Red LED lights	Register or verify or delete user unsuccessfully	Three Beeps
4	Blue LED lights	Enter main menu	Buzzer not ring
5	Orange LED lights	Enter register or other operation mode	Buzzer not ring
6	Red LED fast flashing	Tamper alarm rings	Long Voice

Working with Management Software

1. Install the Management Software on Computer

Put the CD in the management computer. The installation program will run automatically.

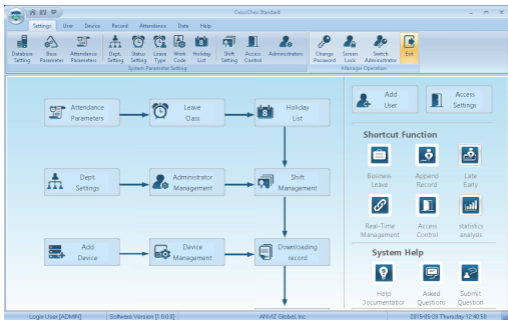

How to connect M3 with Software?

1st Method: Mini USB

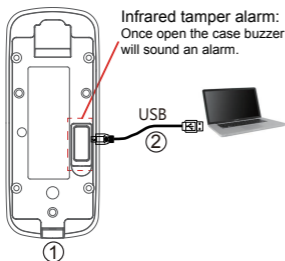

① Loose the screw on the bottom of M3, then pull up the front case, separate from back panel

② Connect USB cable between with M3 and PC which has installed software

2nd Method: Connect M3 to Network

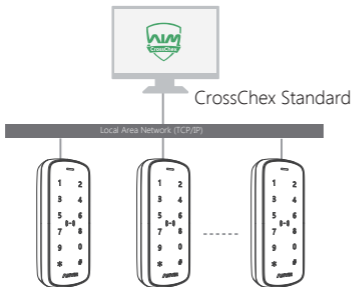

2. Enable Communication between M3 and the Management Software CrossChex

- *Turn on management software CrossChex
- *Go to Device tab. Search and Add the M3 to management software CrossChex
- *Click Synchronize Time button to communicate with M3. If Synchronize is successful, the device icon will turn to blue.

3. The Management Software CrossChex Features

- *Device\Backup User: Download user info from M3 to CrossChex
- *Device\Download Records: Download records from M3 to CrossChex
- *User\Modify: Edit name or other user info. Then click 'Upload User' to Upload user info to M3 device
- *Record\Search: Search and view the records
- *Attendance: Calculate, Search results and Generate reports
- *Data\Backup Database: Backup Database
- *Setting\Shift: Set up Time Table and Scheduling
- *Device\Device Parameter: Set up device, Clear records on M3 or Reset M3 to factory settings

Have a question? Please feel free to send emails to support@anviz.com to get support.



About Anviz

Founded in 2001, Anviz is a global leader in the field of intelligent security including Biometric, RFID and Surveillance. Cutting edge R&D, ISO certified manufacturing and global brand recognition provide our partners with the fast track to success!

Anviz is at the forefront of biometric, RFID, and surveillance technologies. Through constant R&D, ISO certified manufacturing and global brand recognition, Anviz is an industry leader. Producing high-quality, cost-effective security solutions have helped amass a global client base of over 60 million customers in over 100 countries.

For more information, visit www.anviz.com or email us press@anviz.com

2016 © Anviz Global. All Rights Reserved. Due to the consistent improving of the product, this specification and appearance is subject to change without notice.